

NL SERIES

NL5803GPHD

3-needle, flat bed, double chain stitch machine with upper rear puller



Options :

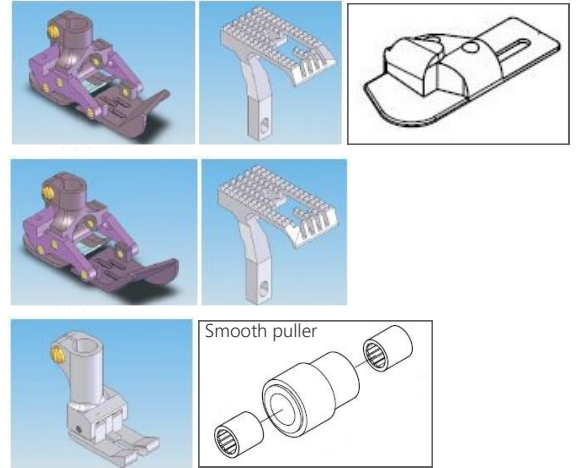
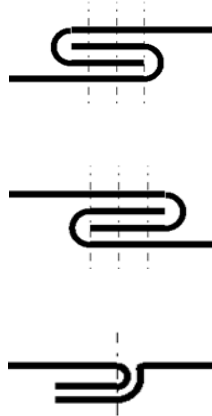

NL5803GVTF

3-needle, flat bed, double chain stitch machine without puller

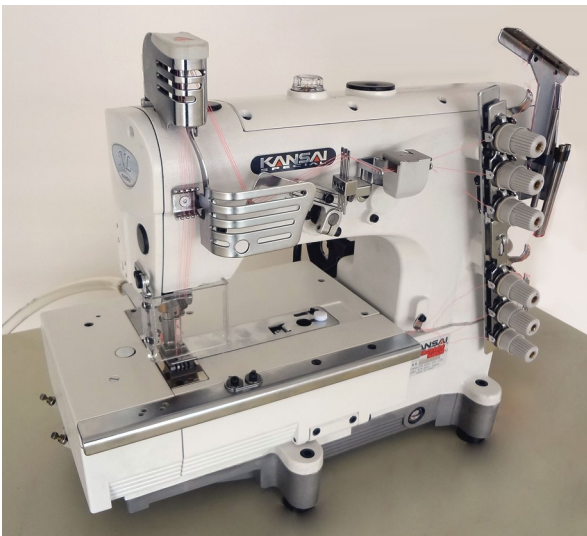

Options :

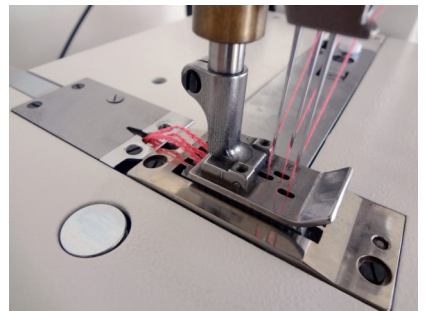
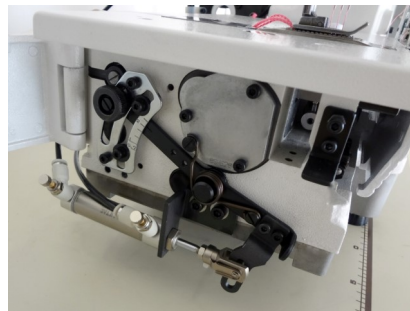

Stitch Condensing Device (CD)

Chain cutter (CS1)

Fabric Weight	Type of Needle	No. of Needle & Thread	Gauge	Needle bar stroke	Stitch length	Diff. feed ratio	Presser foot lift	Max speed
Heavy	TV x 5 #18	3 needles 6 threads	1/4", 3/8", 1/2"	34 mm	2.1 ~ 4.2 mm	N/A	8 mm	4500 rpm ~ 5000 rpm



Double chain stitch machines for various operations on Jeans



NL SERIES

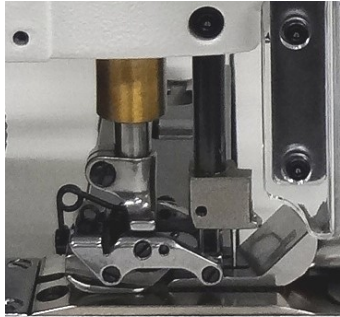

■ DLC coated needle bar



■ New oil seals

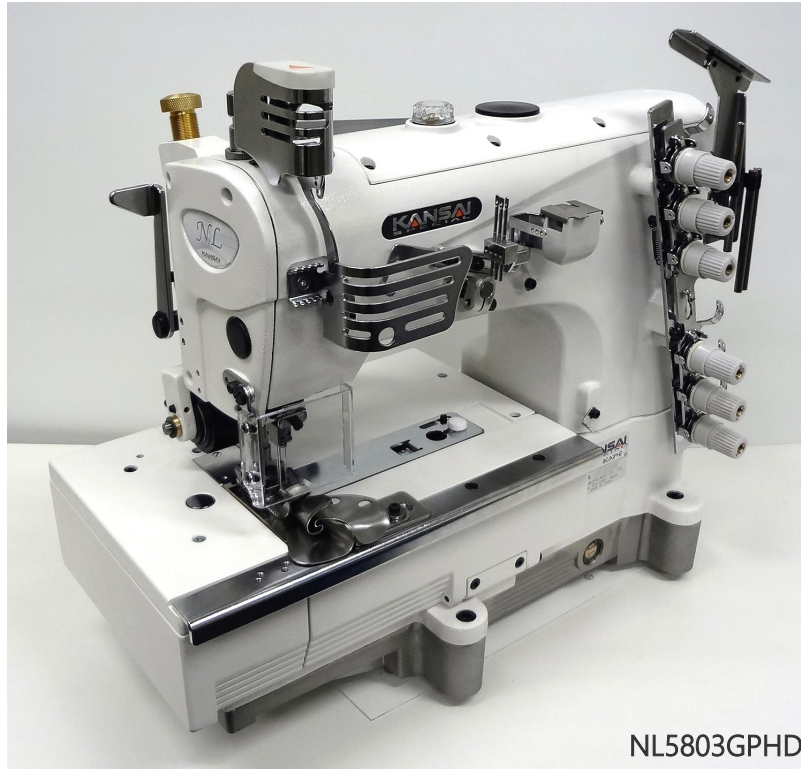

NL5803GPHD

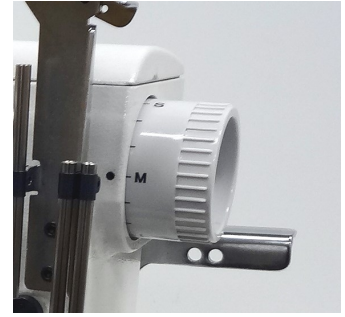

■ New Hand Wheel



■ User-friendly presser foot lifter

This DLC (Diamond-Like Carbon) coated needle bar ensures the durability and the stability. The new oil seals equipped on the needle bar and the presser foot bar prevent oil leakage and protect your sewn products from oil stains.

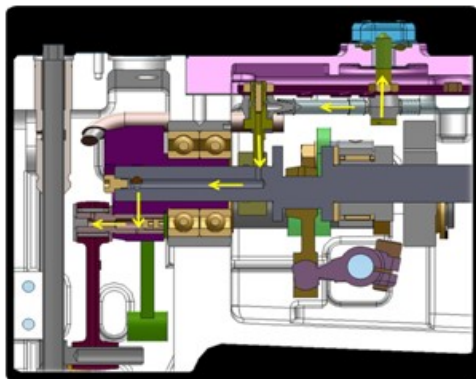

■ New lubrication system

This new lubrication system through the needle bar link bearing reduces noise and vibration.

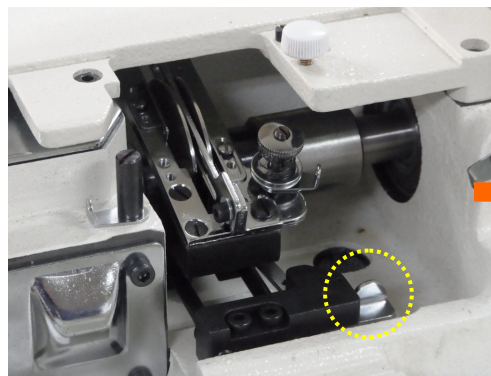

■ Slide-out thread take-up system

Pull the lever and the looper thread-take up cam will slide toward the operator. This simplifies threading and troubleshooting.

